

DIFFERENT OPTIONS FOR COLUMN BRACING

P/N: 6000093

TOP COLUMN ANCHOR PLATE

COLUMN BRACING 1

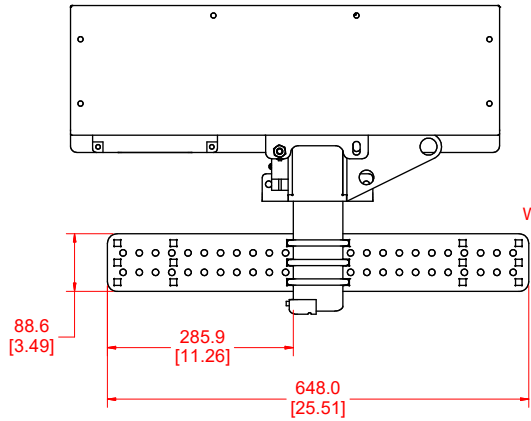

LOCKNUT WITH WASHER

25.4 [1.00]

U-BOLT (3X) WITH LOCKNUT & WASHER

P/N: 6000093
TOP COLUMN ANCHOR PLATE

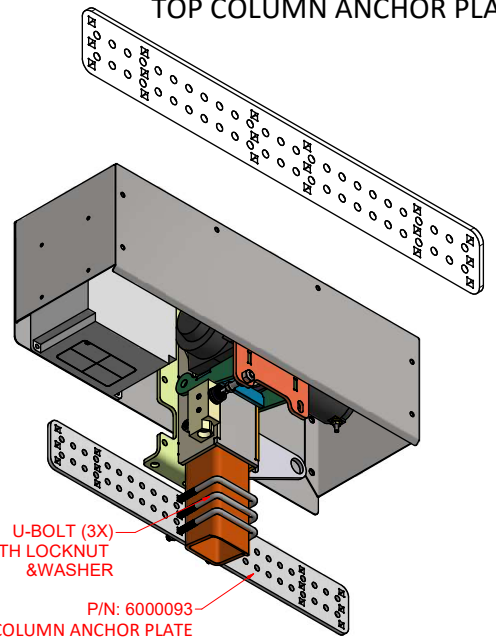

COLUMN BRACING 2

P/N: 6000049
BASE BRACKET

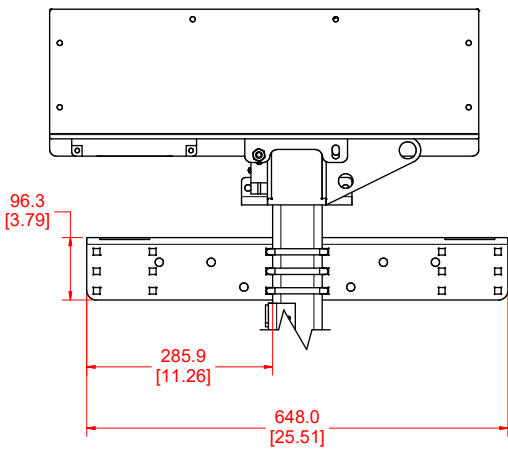

LOCKNUT WITH WASHER

86.7 [3.41]

25.4 [1.00]

U-BOLT (3X) WITH LOCKNUT & WASHER

P/N: 6000049
BASE BRACKET

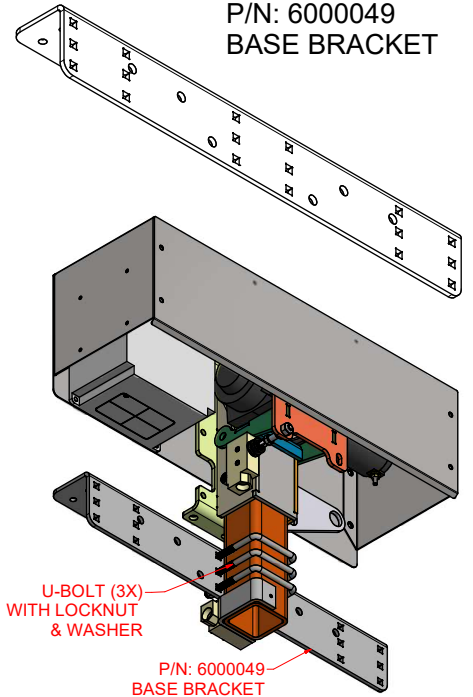

COLUMN BRACING 3 (TIGHTENING NUT ON OPERATOR SIDE)

P/N: 6000089
COLUMN CLAMP PLATE

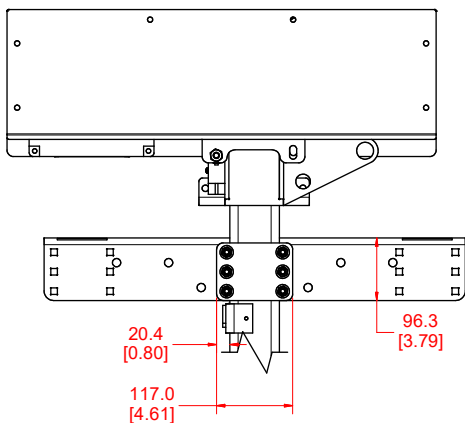

CARRIAGE BOLT WITH WASHER AND LOCKNUT(6X)

6000089
COLUMN CLAMP PLATE (OPERATOR SIDE)

LOCKNUT WITH WASHER

31.8 [1.25]

6000089
COLUMN CLAMP PLATE (OPERATOR SIDE)

CARRIAGE BOLT WITH WASHER AND LOCKNUT(6X)

6000093
TOP COLUMN ANCHOR PLATE

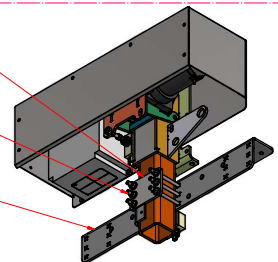
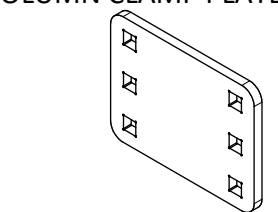
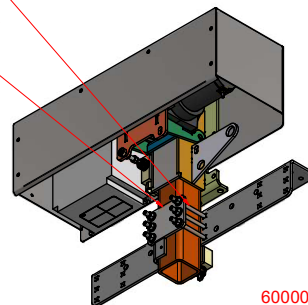

<small>PRIMARY DIMENSIONS ARE IN MILLIMETERS. DIMENSIONS IN INCHES ARE IN PARENTHESES AND ARE REFERENCE ONLY.</small> <small>DO NOT SCALE PRINT</small> <small>IF YOU HAVE QUESTIONS CONCERNING THIS DRAWING OR NEED ADDITIONAL INFORMATION, PLEASE CONTACT YOUR SALES/TEAM FOR ASSISTANCE.</small>	KM SERVICES LLC., LYNCHBURG, VA 24502 DATE: 5/26/2024 DRAWN: MKS DESIGNED: MKS CHECKED: MKS SHEET: 1 OF 7 SCALE:	1:1 REV: 00
	DWG TITLE: DIFFERENT OPTIONS FOR COLUMN SUPPORT DWD NUMBER: PB00002	00

COLUMN BRACING 4

DIFFERENT OPTIONS FOR COLUMN BRACING

P/N: 6000089
COLUMN CLAMP PLATE

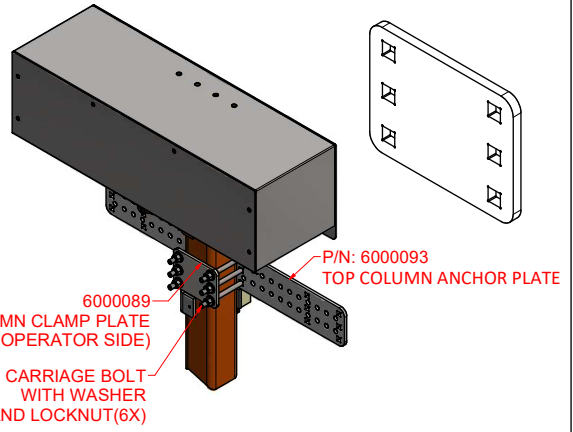
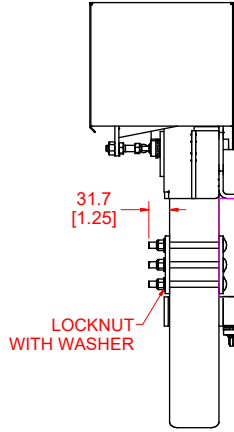
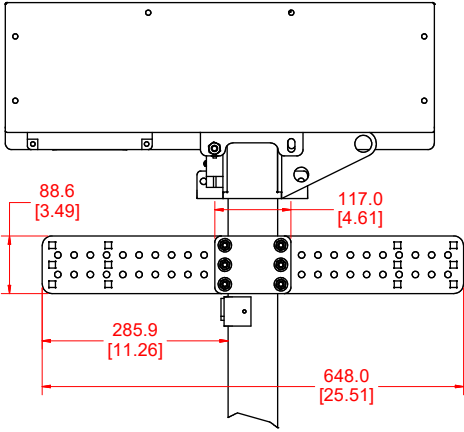

COLUMN BRACING 5

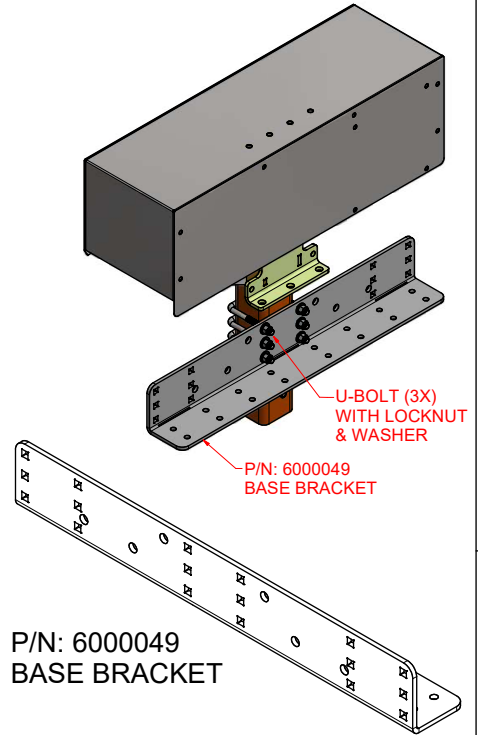
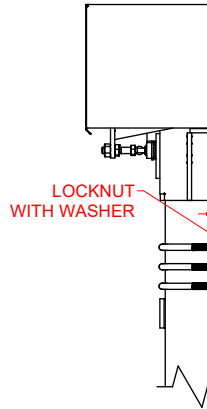
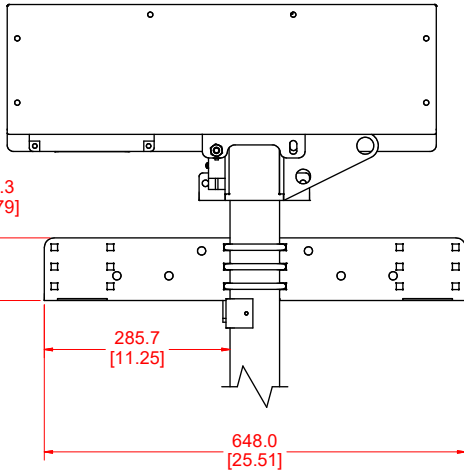

COLUMN BRACING 6 (OFFSET MOUNTING)

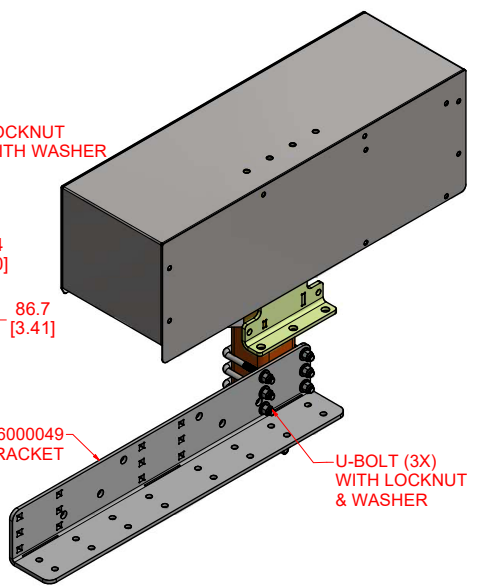
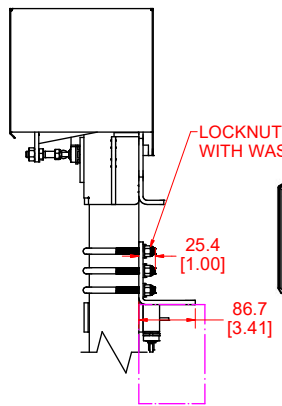
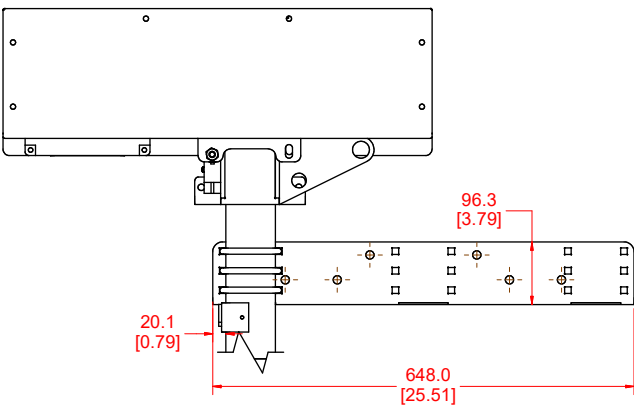

P/N: 6000049
BASE BRACKET

<p>PRIMARY DIMENSIONS ARE IN MILLIMETERS. DIMENSIONS IN PARENTHESES ARE IN INCHES AND ARE REFERENCE ONLY.</p> <p>THIRD ANGLE PROJECTION</p> <p>DO NOT SCALE PRINT</p> <p>IF YOU HAVE QUESTIONS CONCERNING THIS DRAWING OR NEED ADDITIONAL INFORMATION, PLEASE CONTACT YOUR SALESMAN FOR ASSISTANCE.</p>	<p>KM SERVICES LLC., LYNCHBURG, VA 24502</p> <p>DWG TITLE</p> <p>DIFFERENT OPTIONS FOR COLUMN SUPPORT</p> <p>DWG NUMBER</p> <p>PB00002</p>	<p>DRAWN: MKS</p> <p>DATE: 5/28/2024</p> <p>BY: MKS</p> <p>SCALE: 1 OF 7</p> <p>SCALE: 1 : 25</p> <p>REV: 00</p>
	<p>1</p>	

COLUMN BRACING 7

P/N: 6000274
BASE BRACKET

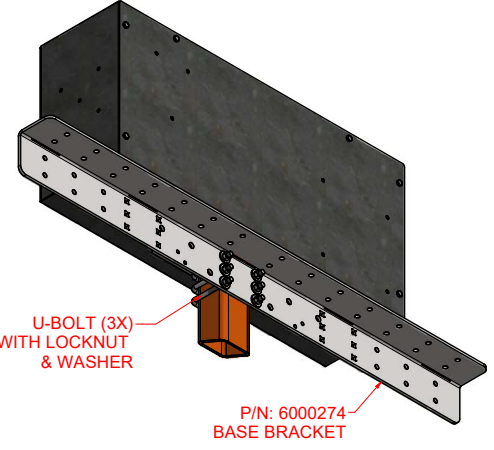
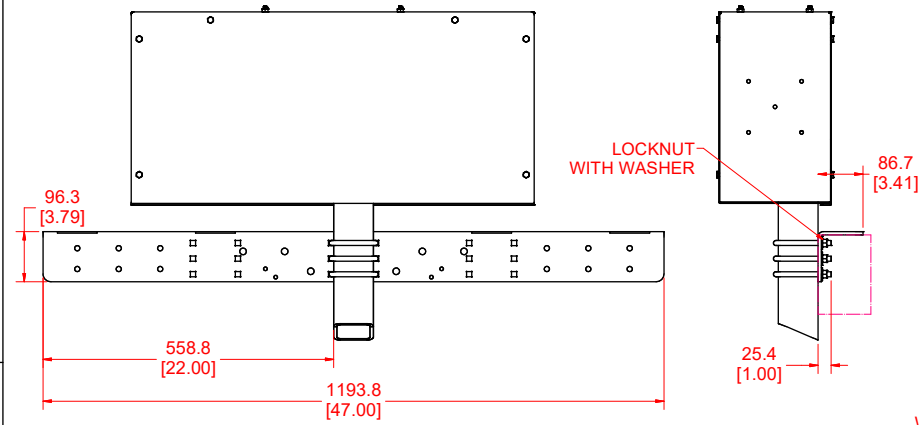

COLUMN BRACING 8
(TIGHTENING NUT ON OPERATOR SIDE)

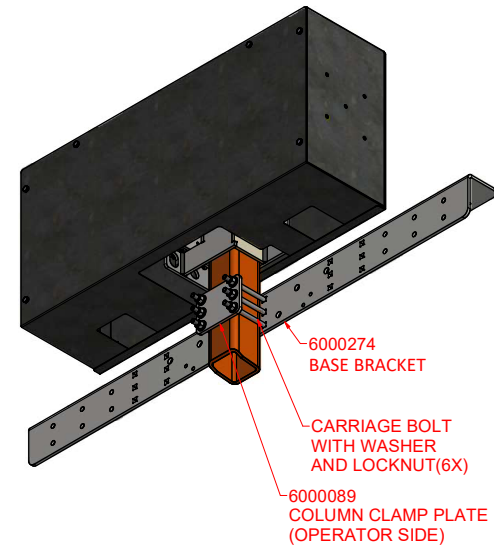
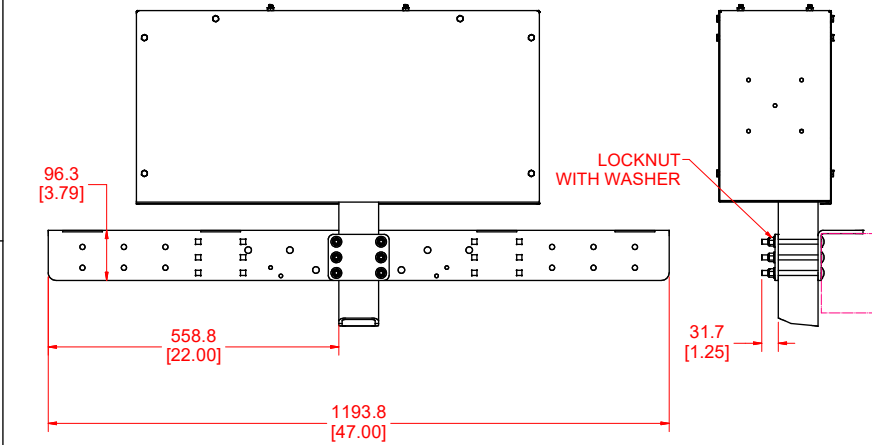

COLUMN BRACING 9

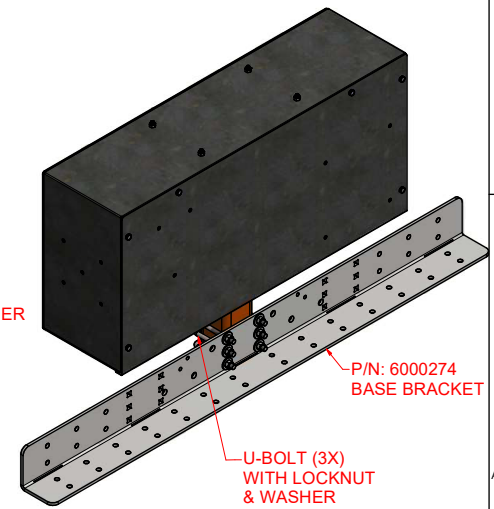
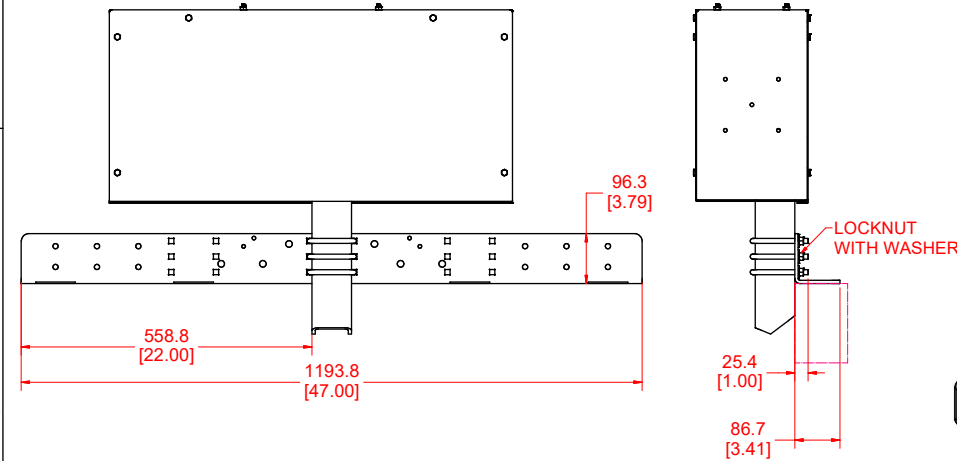

<small>PRIMARY DIMENSIONS ARE IN MILLIMETERS. DIMENSIONS IN PARENTHESES ARE IN INCHES AND ARE REFERENCE ONLY.</small> <small>DO NOT SCALE PRINT</small> <small>IF YOU HAVE QUESTIONS CONCERNING THIS DRAWING OR NEED ADDITIONAL INFORMATION, PLEASE CONTACT YOUR SALESMAN FOR ASSISTANCE.</small>	KM SERVICES LLC., LYNCHBURG, VA 24502 DWG TITLE DIFFERENT OPTIONS FOR COLUMN SUPPORT	DRAWN: MKS DATE: 5/29/2024 DESIGNED: KMS SIZE: D SHEET: 1 OF 7 SCALE: 1:6 REV: 00
	DWG NUMBER: PB00002	1

DIFFERENT OPTIONS FOR COLUMN BRACING (BOTTOM)

BOTTOM COLUMN BRACING FOR BASE BRACKET LIFT -OPTION 1

P/N: 6000274
BASE BRACKET

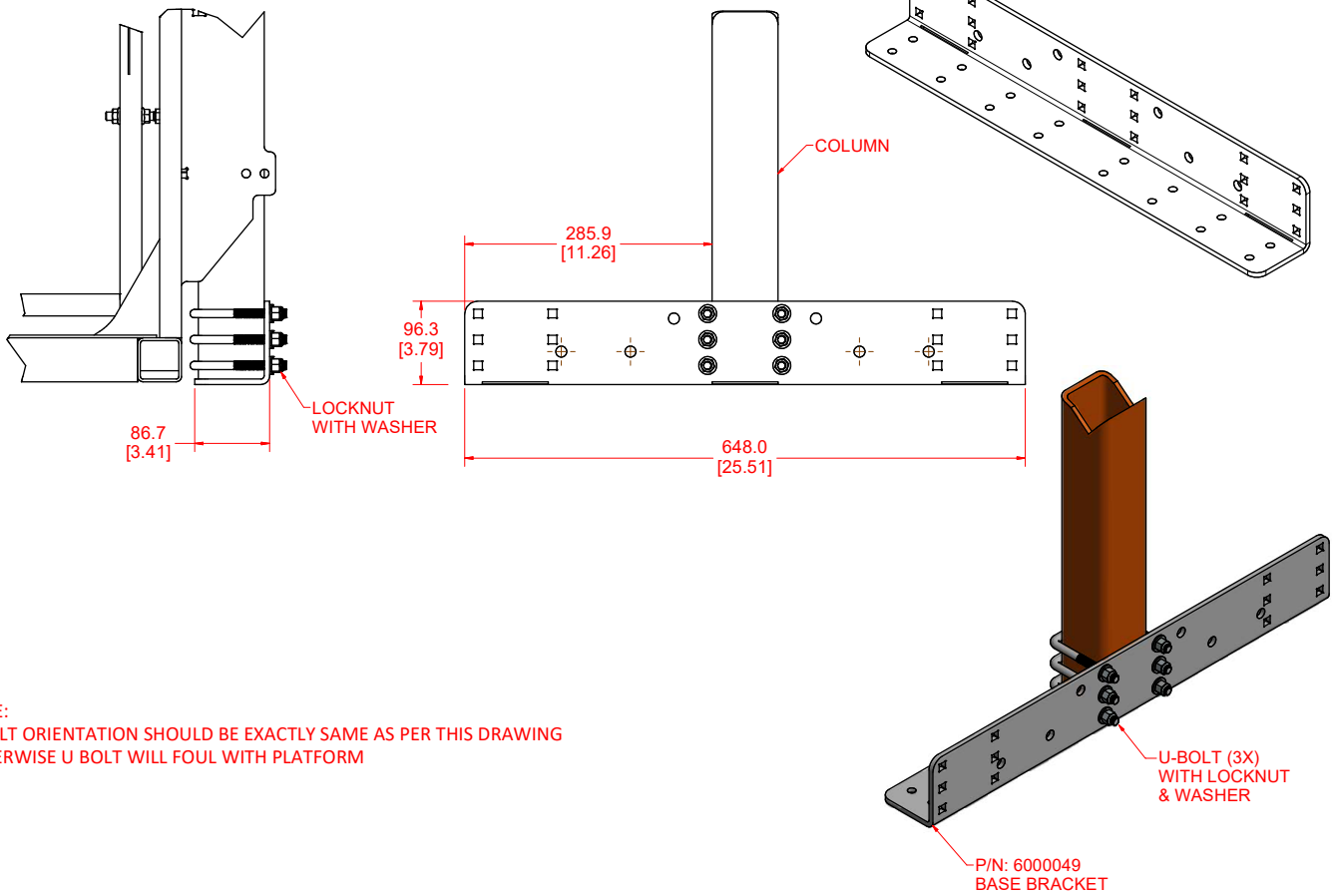

NOTE:
U BOLT ORIENTATION SHOULD BE EXACTLY SAME AS PER THIS DRAWING
OTHERWISE U BOLT WILL FOUL WITH PLATFORM

BOTTOM COLUMN BRACING FOR BASE BRACKET LIFT -OPTION 2

P/N: 6000274
BASE BRACKET

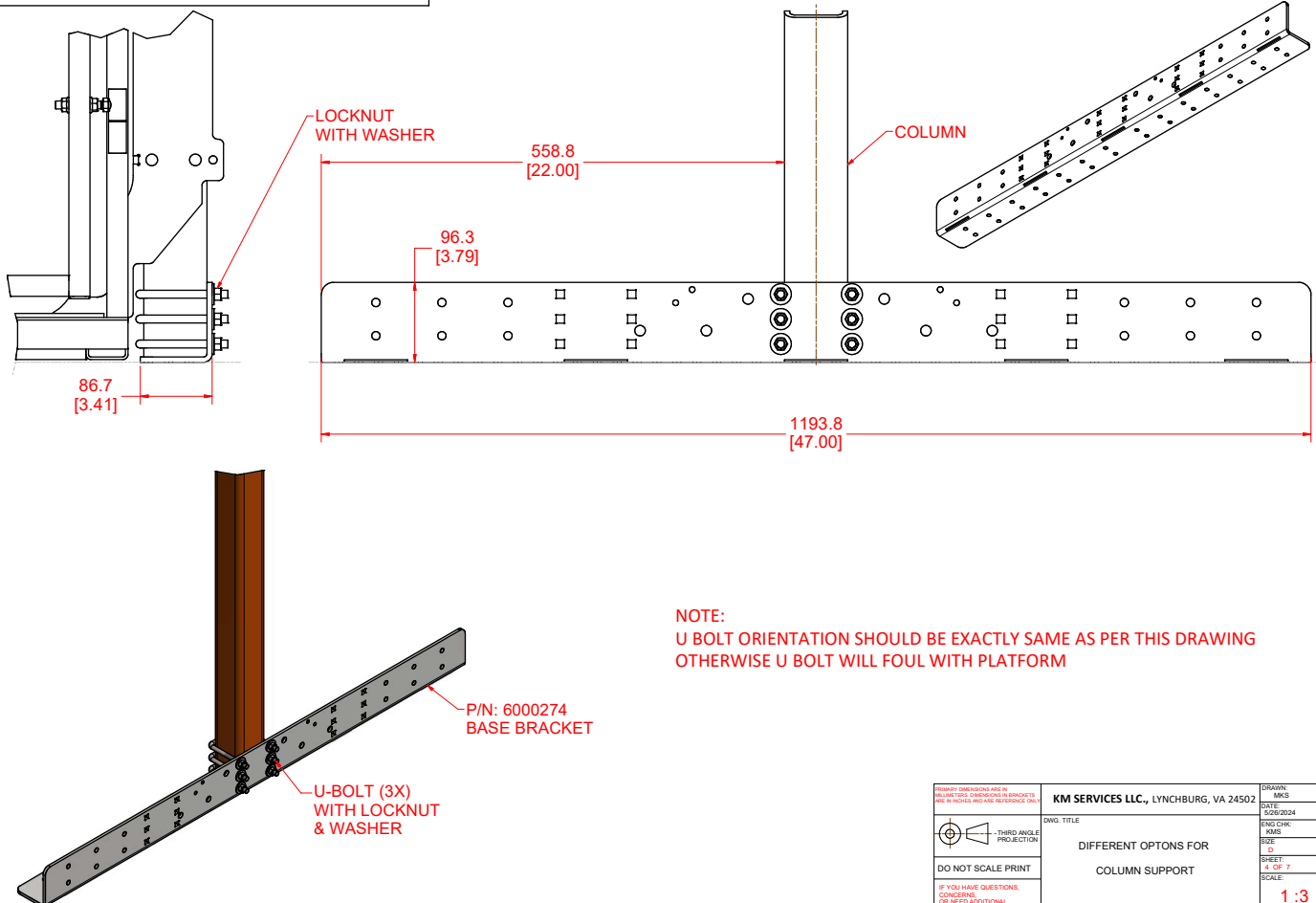

NOTE:
U BOLT ORIENTATION SHOULD BE EXACTLY SAME AS PER THIS DRAWING
OTHERWISE U BOLT WILL FOUL WITH PLATFORM

PRIMARY DIMENSIONS ARE IN MILLIMETERS. DIMENSIONS IN PARENTHESES ARE IN INCHES AND ARE REFERENCE ONLY.	KM SERVICES LLC., LYNCHBURG, VA 24502	DRAWN: MKS DATE: 9/26/2024 SPEC FIRM: KIMS SIZES SHEET 4 OF 7 SCALE 1:3 REV 00
THIRD ANGLE PROJECTION	DWG TITLE DIFFERENT OPTIONS FOR COLUMN SUPPORT	
DO NOT SCALE PRINT IF YOU HAVE QUESTIONS CONCERNING DIMENSIONS OR NEEDS ADDITIONAL INFORMATION, PLEASE CONTACT YOUR SALESMAN FOR ASSISTANCE.	DWG NUMBER PB00002	

DIFFERENT OPTIONS FOR COLUMN BRACING
(BOTTOM)

BOTTOM COLUMN BRACING FOR
ARMED BASE LIFT

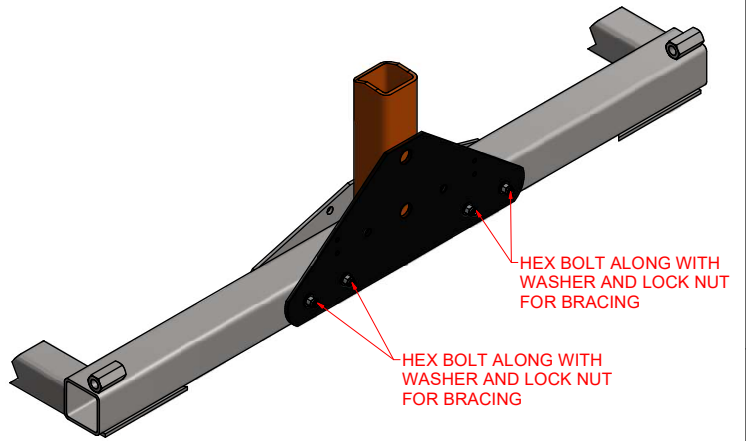
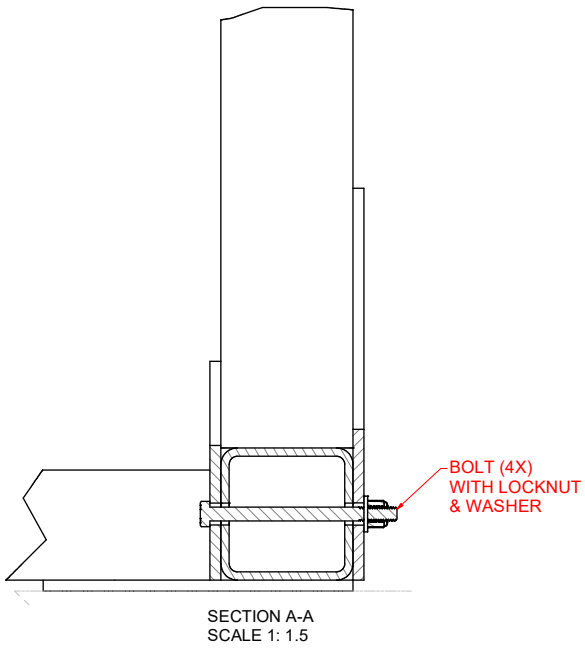
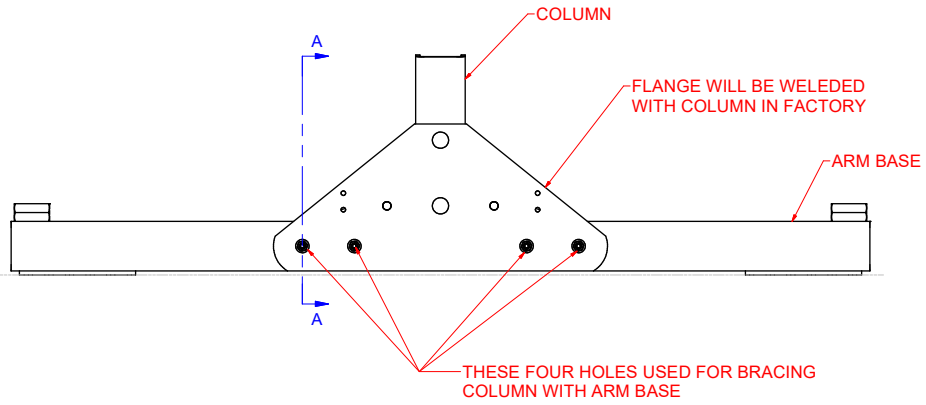

NOTE:
BOLT ORIENTATION SHOULD BE EXACTLY SAME AS PER THIS DRAWING
OTHERWISE BOLT WILL FOUL WITH PLATFORM

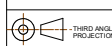
<small>PRIMARY DIMENSIONS ARE IN INCHES UNLESS OTHERWISE SPECIFIED IN DIMENSIONS IN PARENTHESES OR IN NOTES UNLESS OTHERWISE SPECIFIED. DIMENSIONS ARE IN INCHES AND ARE REFERENCE DIMENSIONS.</small>  <small>DO NOT SCALE PRINT</small> <small>IF YOU HAVE QUESTIONS CONCERNING THIS DRAWING OR NEED ADDITIONAL INFORMATION, PLEASE CONTACT YOUR SALES/ENGINEER FOR ASSISTANCE.</small>	KM SERVICES LLC., LYNCHBURG, VA 24502 <small>DWG. TITLE</small> DIFFERENT OPTIONS FOR COLUMN SUPPORT	<small>DRAWN:</small> MKS <small>DATE:</small> 5/28/2024 <small>DESIGNED BY:</small> MKS <small>CHECKED BY:</small> MKS <small>SHEET:</small> 5 OF 7 <small>SCALE:</small> 1 : 25
	<small>DWG. NUMBER</small> PB00002	<small>REV</small> 00

DIFFERENT OPTIONS FOR COLUMN BRACING PART DRAWINGS

P/N: 6000049
BASE BRACKET

16X Ø10.00 THRU
USED FOR STRUCTURE MOUNTING

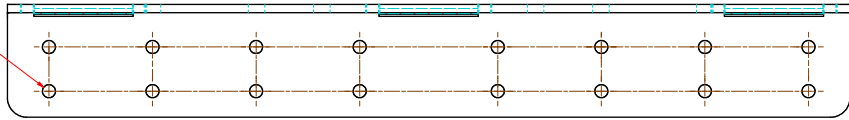
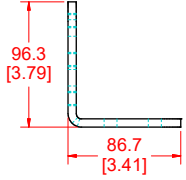

ALL SQ SHAPE HOLES USED FOR CARRIAGE BOLT.
FOR U BOLT APPLICATION ONLY THREAD SIDE ALLOWED

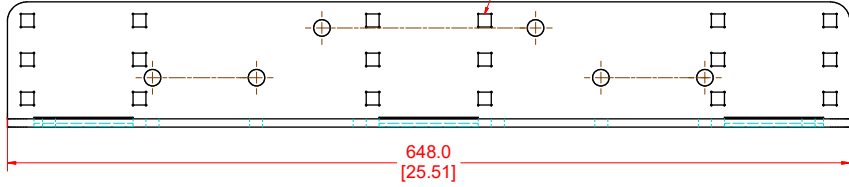

P/N: 6000089
COLUMN CLAMP PLATE

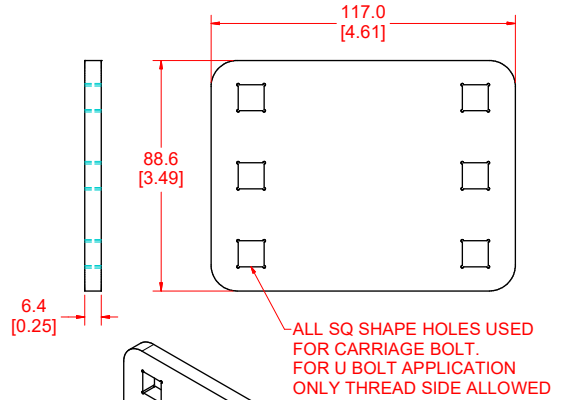
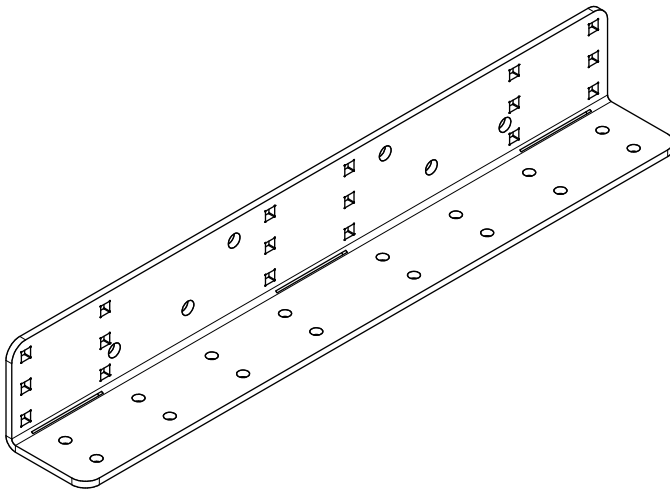

P/N: 6000093
TOP COLUMN ANCHOR PLATE

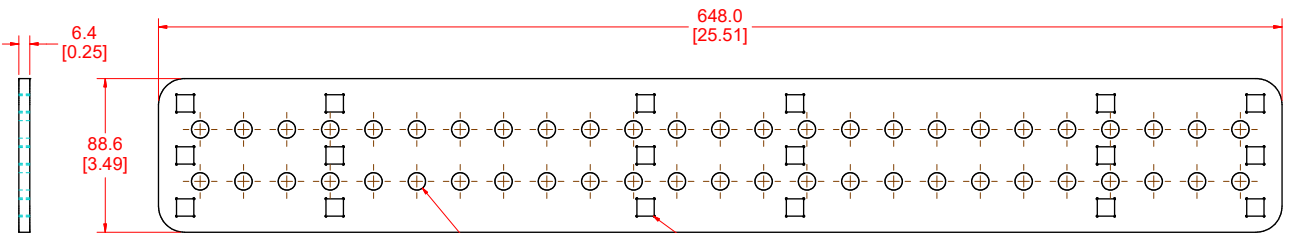

50X Ø10.00 THRU
USED FOR STRUCTURE MOUNTING

ALL SQ SHAPE HOLES USED FOR CARRIAGE BOLT.
FOR U BOLT APPLICATION ONLY THREAD SIDE ALLOWED

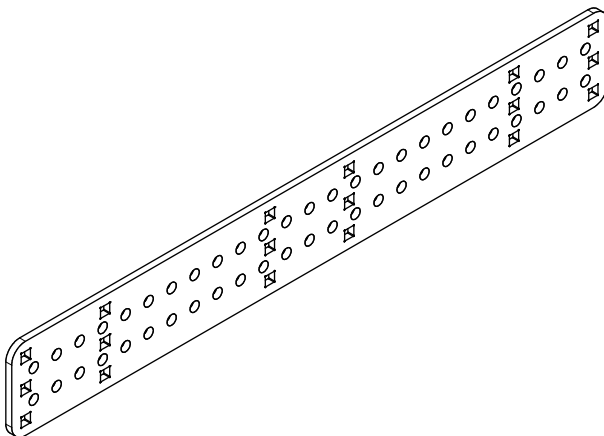

<small>PRIMARY DIMENSIONS ARE IN MILLIMETERS. DIMENSIONS IN PARENTHESES ARE IN INCHES AND ARE REFERENCE ONLY.</small> 	KM SERVICES LLC., LYNCHBURG, VA 24502 <small>DRAWN: MKS</small>	
	<small>DATE: 5/28/2024</small>	
<small>DO NOT SCALE PRINT</small>	<small>DESIGNED BY: KMS</small>	
<small>IF YOU HAVE QUESTIONS CONCERNING THIS DRAWING OR NEED ADDITIONAL INFORMATION, PLEASE CONTACT YOUR SALESMAN FOR ASSISTANCE.</small>	<small>DIFFERENT OPTONS FOR COLUMN SUPPORT</small>	
	<small>DWG NUMBER: PB00002</small>	<small>SCALE: 1:2</small>
	<small>REV: 00</small>	

P/N: 6000274
 BASE BRACKET

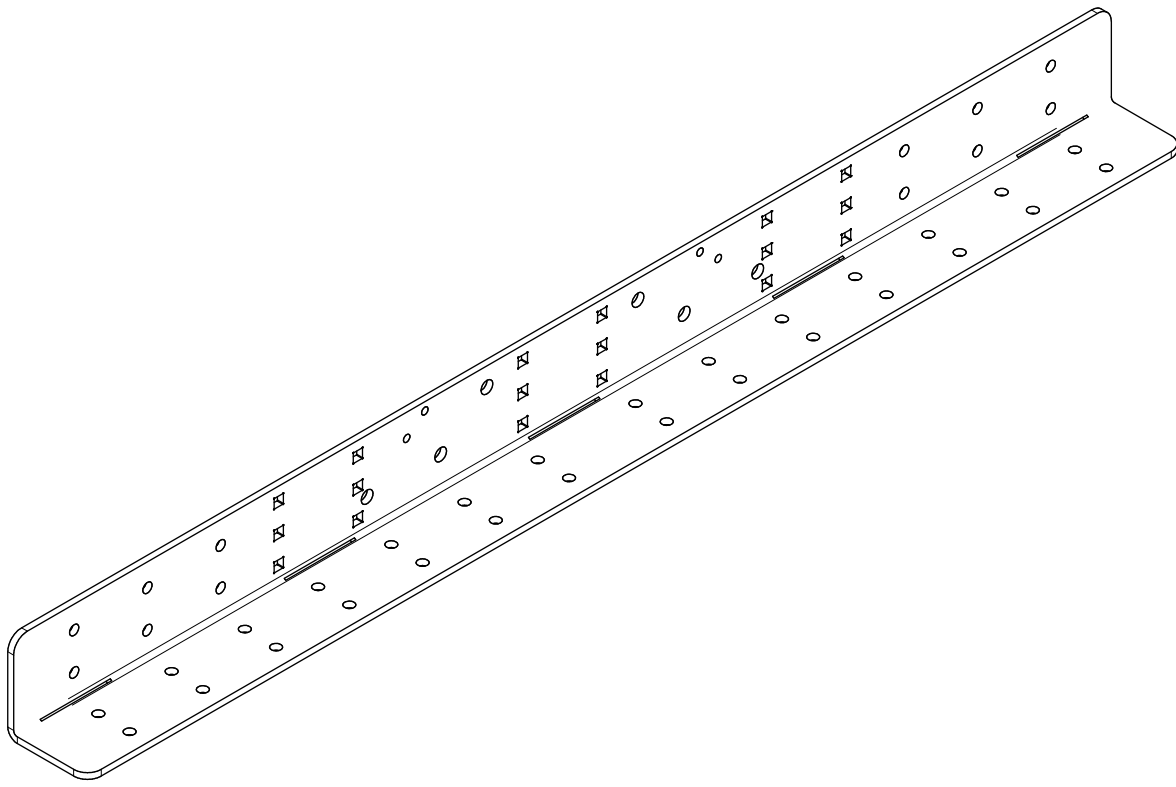
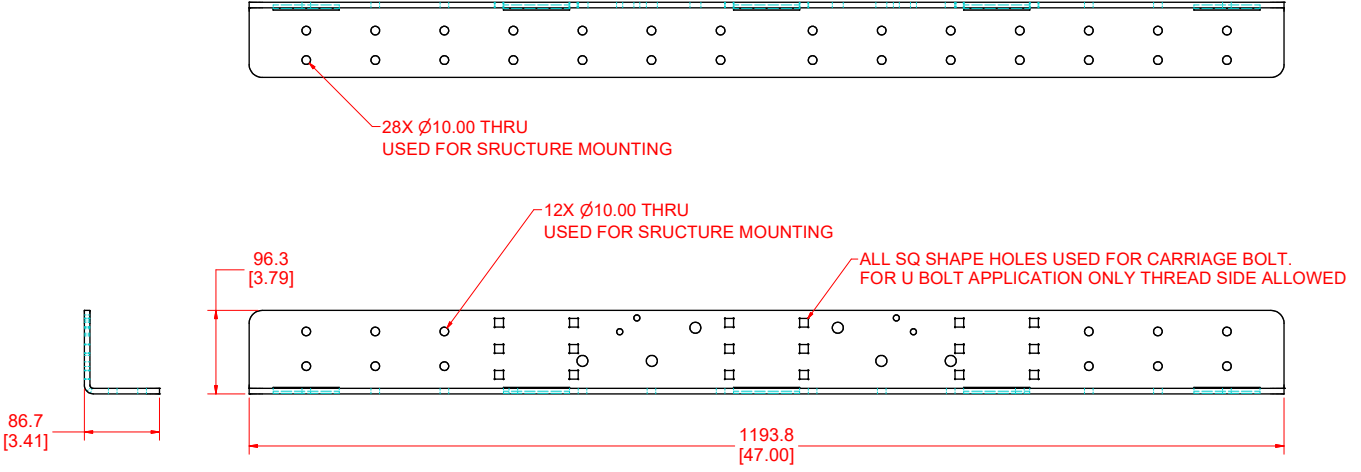

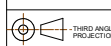
<small>PRIMARY DIMENSIONS ARE IN MILLIMETERS. DIMENSIONS IN PARENT INCHES ARE FOR REFERENCE ONLY.</small>  <small>DO NOT SCALE PRINT</small>	KM SERVICES LLC., LYNCHBURG, VA 24502 <small>DWG TITLE</small> DIFFERENT OPTIONS FOR COLUMN SUPPORT	<small>DRAWN:</small> MKS <small>DATE:</small> 5/28/2024 <small>DESIGNED BY:</small> KMS <small>CHKD BY:</small> D <small>SHEET</small> 1 OF 7 <small>SCALE</small> 1:3
	<small>IF YOU HAVE QUESTIONS, CONCERNING OR NEED ADDITIONAL INFORMATION, PLEASE CONTACT YOUR SALESMAN FOR ASSISTANCE.</small>	<small>DWG NUMBER</small> PB00002